



*picture shown with optional infeed & outfeed table and casters

 **WEXXAR BEL®**

BEL 450

POLY BAG INSERTER & PACK STATION WITH SEMI-AUTOMATIC TOP & BOTTOM CASE TAPER

EoL

END OF LINE

BEL 450

POLY BAG INSERTER & PACK STATION WITH
SEMI-AUTOMATIC TOP & BOTTOM CASE TAPER

BEL 450 HYGIENIC POLYBAG CASE OPENING

The BEL 450's vacuum plenums open up polybags without the need for the operator to handle the inside of the bags for quick and hygienic case packing.

Hygienic Packing for Poly Bags in Cases

The BEL 450 is a compact and efficient poly bag inserter, pack station and semi-automatic case sealer. The machine features a vacuum system which draws the poly liner flush against the box to allow the operator to begin packing.

Case filling can be controlled with the optional programmable weigh scale which can be interfaced with a variety of filling machines. When combined with a bag roller and KDF Box stand, the BEL 450 is an ergonomic and productive solution for manual bulk filling and sealing lines.



ABOUT THE BEL 450



EASY CASE SIZE CHANGES

Tool-less case size changes are simple and quick with change points accessible from both operational sides of the machine.

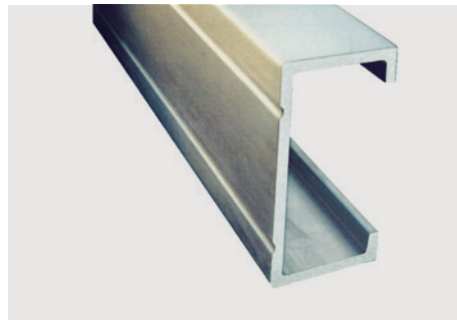

LASTING PERFORMANCE

Corrosion resistant and paint-free construction guards against machine wear and extends machine life.



ON MACHINE INSTRUCTIONS

User-friendly pictorial guides and color-coded labeling for convenient operation and size changes.

COMPLETE SOLUTION

FULLY AUTOMATE YOUR PACKAGING LINE WITH THESE FORMING AND PACKING SOLUTIONS.



S10 WEIGH SCALE

The S10 weigh scale allows for precise packing, achieving the desired weight in every case. It can also interface with a variety of fillers and loaders.



ACCUMULATION TABLE

Ensures product is delivered continuously and ergonomically to the operator. This allows convenient and quick packing as it keeps the product in reach of the operator.



KDF BOX STAND

One of the most popular accessories for semi-automatic packaging lines. The box stand holds case blanks in a convenient position for quick and ergonomic packing.

CONFIGURATION

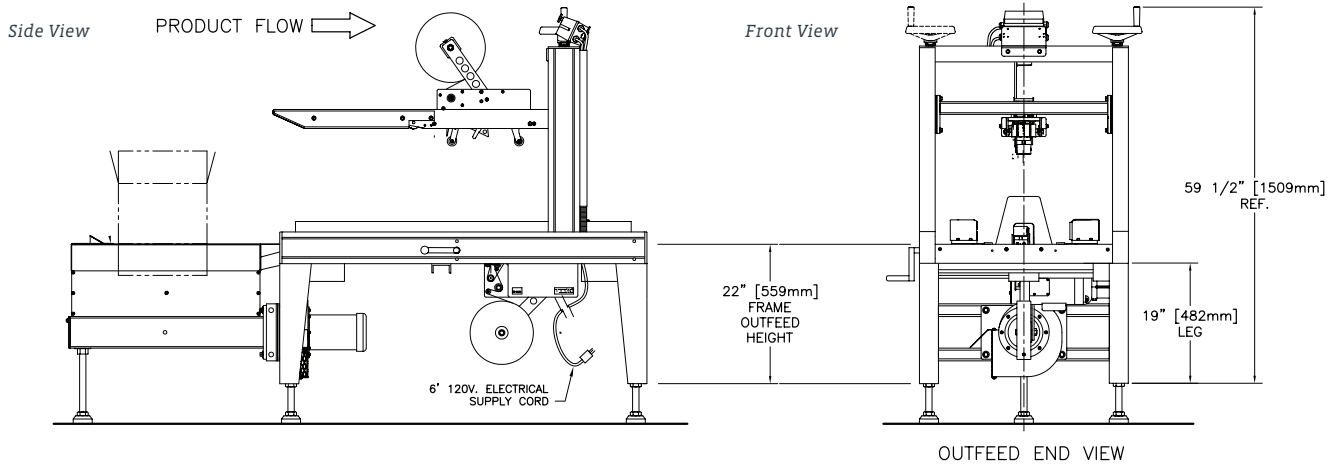

FEATURES AND BENEFITS

- Efficient and ergonomic packaging solution for poly-bag packaging
- Exclusive Uni-Drive squaring technology that provide consistent and uniform seal on cases
- Designed and built in North America with premium materials Simple and quick operation and maintenance
- Reliable, consistent “no break” tape advance with DEKKA 22 Stainless Steel 2” tape heads

OPTIONAL MODIFICATIONS

- Modifications for undersized or oversized cases
- Ergo Level Modification
- Custom Guarding

OPTIONAL ACCESSORIES

- Locking Casters
- Outfeed Table or Conveyor
- Accumulation Table
- S10 Weigh Scale
- KDF Box Stand with Bag Roller

PRODUCT SPECIFICATIONS

Machine Weight	650 lbs
Machine Dimensions	92"(L) x 33"(W) x 59.5"(H)
Electrical	120 Volts, 1 PH, 60 Hz - 15 amp draw
Speeds	up to 5 cases / min.

CASE SIZE RANGE

	LENGTH	WIDTH	HEIGHT
Minimum	8" 203 mm	5 1/2" 140 mm	4" 102 mm
Maximum	24" 609mm	17 3/8" 441 mm	21" 533 mm

INFEED/OUTFEED HEIGHT

Minimum	24.4" (620 mm)
Maximum	32" (813 mm)

Specifications are subject to change without notice.

FOR MORE INFORMATION:
(604) 930-9300 • Wexxar.com



At Wexxar Bel, corrugated container packaging applications are limited only by the imagination. Our Wexxar case formers and case sealers have been installed in nearly 40 countries and consistently bring customers the lowest cost of ownership and the highest standards of safety. Wexxar also offers the BEL line of corrugated box sealers, tapers, and packing systems as well as the IPAK line of tray and bliss formers, stackers, and sealers systems. As part of the ProMach End of Line business line, Wexxar helps our packaging customers protect and grow the reputation and trust of their consumers. ProMach is performance, and the proof is in every package.

13471 Vulcan Way

Richmond, BC, Canada

P: (604) 930-9300

F: (604) 930-9368

E: Wexxar@ProMachBuilt.com

Wexxar.com